

# RE-451

代表用途 (Typical Applications)

- ・電動工具            Electric tool
- ・ポンプユニット    Pump unit



寸法図 (Dimension)

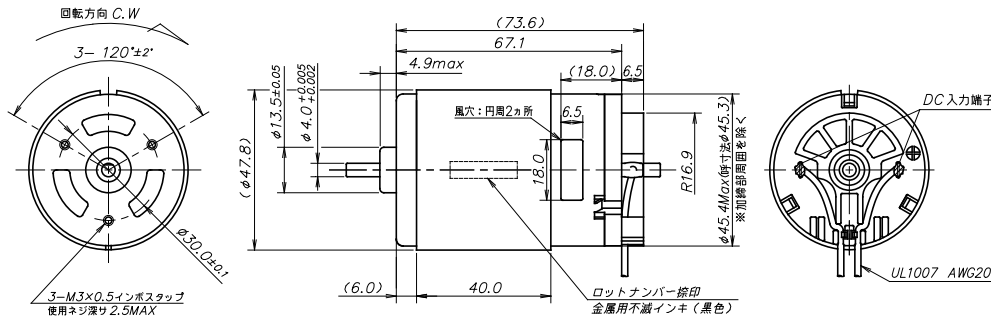

参考特性 (Reference characteristics)

定格電圧 Rated Volt (V)	無負荷回転数 No load speed (r.p.m)	無負荷電流 No load current (mA)	定格トルク Rated torque (g.cm)	定格回転数 Rated speed (r.p.m)	定格電流 Rated current (mA)	停動トルク Stall torque (g.cm)
12V D.C	5000	350	900	3800	4000	3750
18V D.C	4750	250	900	3800	2600	4500

特性図 (Characteristics)

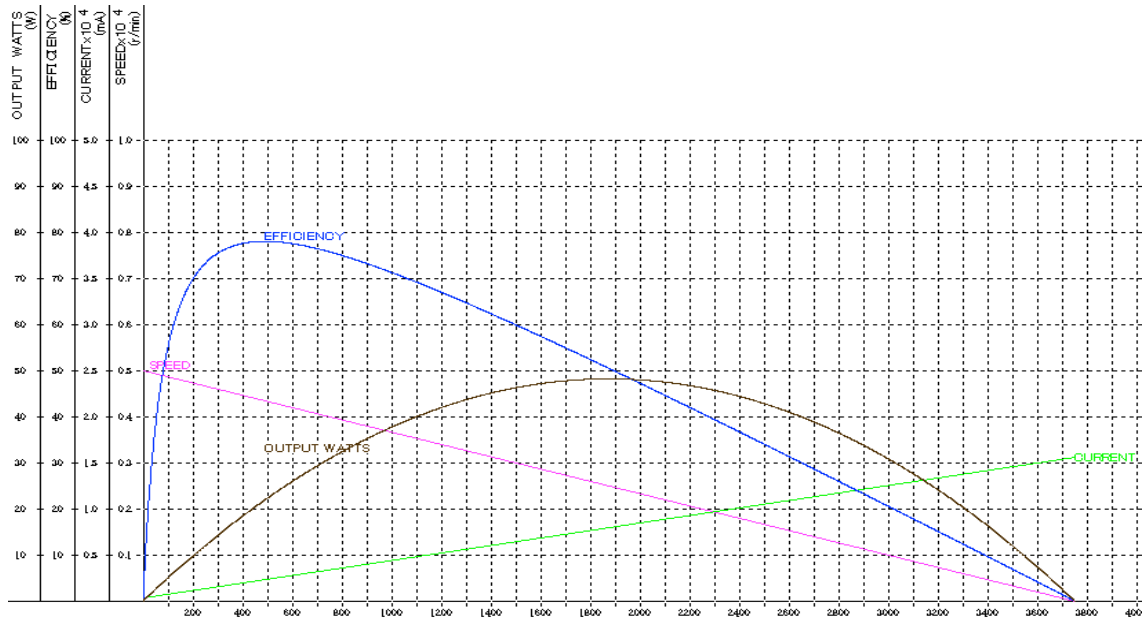

株式会社 NEXT

〒260-0822 千葉県千葉市中央区蘇我2丁目30-31

TEL : 043-309-8006

FAX : 043-309-8016